



"we supply the goods to keep you growing"

www.AmericanHort.com | (800) 247-1184

Cultivate '23 10% Show Discount + Free Freight

DRUM SOWING LINE – 1400 trays/h

Price summary

- ✓ Tray filler R9G
- ✓ Destacker Type 3
- ✓ Seeder S9A
- ✓ Vermiculite dispenser + Water tunnel, Euro

Total Price, USD

~~\$106,845.95~~ + freight

\$96,161.35 (taxes not included)

Delivered anywhere in the continental United States

This line is being displayed @ Cultivate'23 and the delivered price is for this unit only.



"we supply the goods to keep you growing"

www.AmericanHort.com | (800) 247-1184

DRUM SOWING LINE – 1400 trays/h

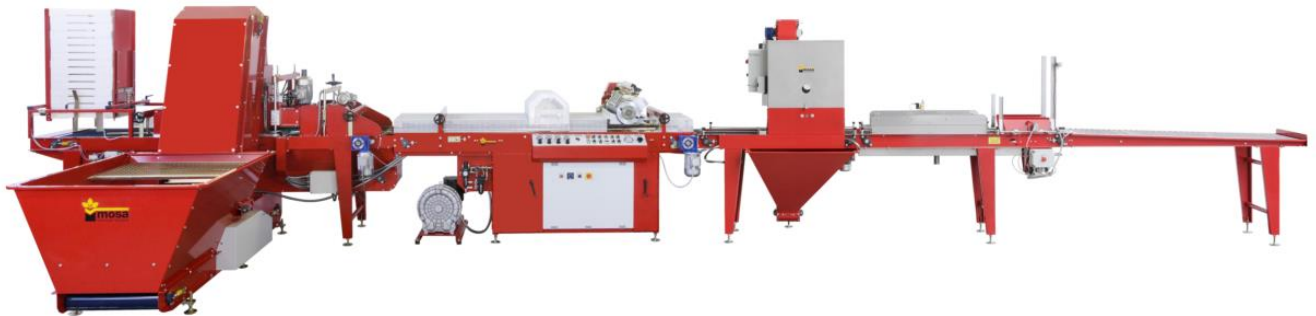

Technical data for standard line:

Minimum speed capacity	1 single tray
Maximum speed capacity	1.400 trays/h.
Maximum tray dimension	480 mm. (width) x 700 mm. (length) x 1600 mm. (height)
Standard electricity	<u>400</u> or <u>230</u> V. <u>3Phases</u> +N+PE 60 Hz, to be specified at order
Total installed power	9,50 kW
Recommended air compressor	5-7 HP minimum (not included on this quotation)
Total air consumption	500 l./m. – 7 bar

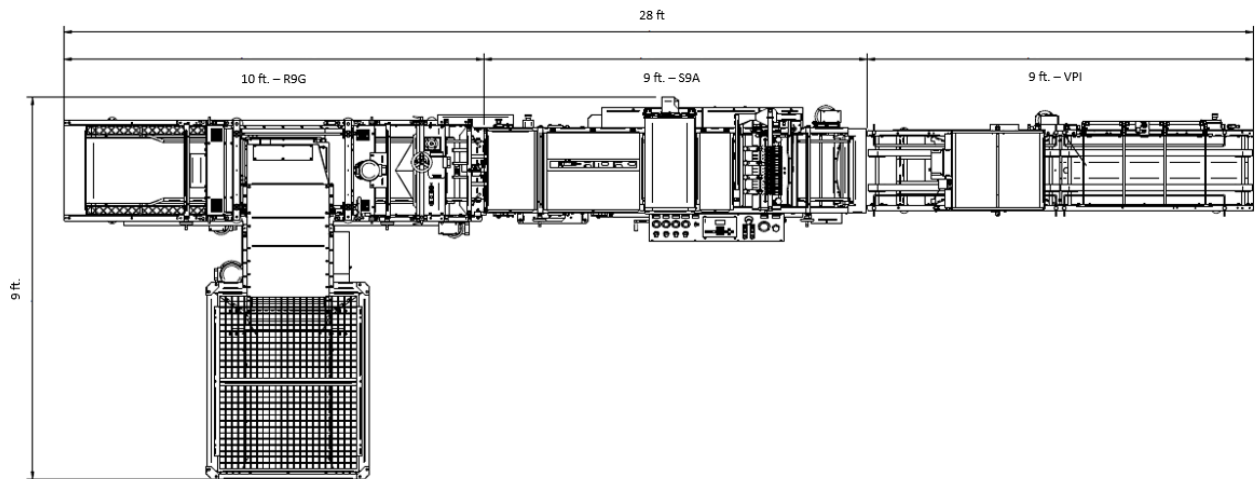



"we supply the goods to keep you growing"

www.AmericanHort.com | (800) 247-1184

R9G, Filling machine

R9G tray filler is the latest generation of high work capacity equipment. It can perform till 1.400 trays/hour with a perfect filling homogeneity on the entire tray, also in very small cells sizes. The compacting system allows special compaction to make the perfect plug consistence also when the plants have to be planted with an automatic transplanting machine for open fields. This unique compacting device ensures homogeneous filling also in very small cells. The speed is adjustable via inverter from the control panel of the drum seeder. Standard supply includes:



- High grip transport conveyor
- Soil hopper with capacity of 1 cubic meter.
- Double helix into soil hopper to facilitate the supply of soil against the elevator
- Recovering line of exceeding soil, dust proof
- Rotating brush to clean out the tray of the exceeding soil
- Electric board and control panel



"we supply the goods to keep you growing"

www.AmericanHort.com | (800) 247-1184

Tray destacker

Automatic type 3 destacker for thermoformed trays



S9A, Drum seeder

The S9A is a professional and technological sowing machine capable to perform 1.400 trays/hour at certain conditions depending on type of tray and seeds used. It has been designed to be jointed to the R9G tray filler and its control panel has all devices to control the entire filling line from operator side. It is equipped with the special and patented Screening, to control the sowing precision and eliminate double seeds. Sowing drums are made in aluminum with very quick interchangeable system. Nozzles from 0,2 up till 0,5 mm. are made in stainless steel to ensure long life on nozzles size and easy cleaning. From 0,6 up till 1,2-1,5 mm. the nozzles are directly drilled into the drum. All motors are driven by inverters.



Standard supply also includes the followings:

- Dibble device (for drum system)
- High pressure continuous nozzles cleaning system
- Double system for double seed removal, "Screening" + mechanical hammers
- Sub-silent 3 KW vacuum pump
- Tray counter
- Electric board and main control panel for the entire line



"we supply the goods to keep you growing"

www.AmericanHort.com | (800) 247-1184

VP Top dressing dispenser and Water station

One unit 3 m. long with double transport belts and recover system to allow the dry recovering and re-using of exceeding covering material. This unit is suitable to distribute dry media like "Vermiculite" or "Perlite". Upper and lower boxes in stainless steel to ensure a long life. Watering tunnel consists of 4 or 6 dripping pipes each one with interception valve.





"we supply the goods to keep you growing"

www.AmericanHort.com | (800) 247-1184

Price summary

- ✓ Tray filler R9G
- ✓ Destacker Type 3
- ✓ Seeder S9A
- ✓ Vermiculite dispenser + Water tunnel, Euro

Total Price, USD

\$96,161.35

This line is being displayed @ Cultivate'23 and the delivered price is for this unit only.

General Terms

Payment

50% @ the time of order.

50% before shipment from Ohio.

Carrier

TBD

Delivery time

TBD

Warranty

12 months from delivery at site

Installation & Taxes

Not included